

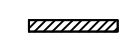

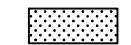

-  Marked or intended crossing location
-  Sidewalk
-  Turning space
Min. level area 4' x 4'
4' x 5' when constrained (with longer dimension in direction of ramp travel).
For the purposes of this application, a max. 2.0% finished surface slope (for drainage) is considered level.
-  Truncated dome detectable warning surface
-  Slope 1.5% max.
(Max. 2.0% finished surface slope)
(Normal sidewalk cross slope)
-  Slope 7.5% max.
(Max. 8.3% finished surface slope)
(Ramp length 15' max.)
-  * 2' See general note 5



OPTION A
PERPENDICULAR RAMP WITH LANDSCAPED BUFFER STRIP

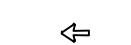
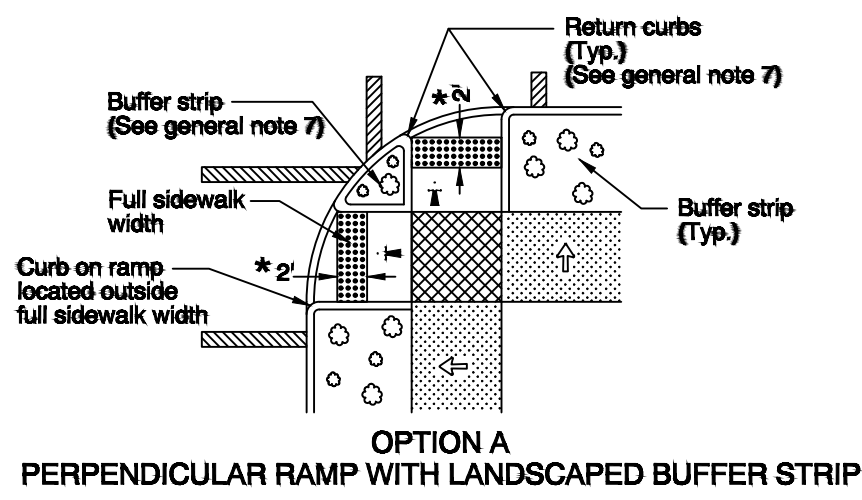
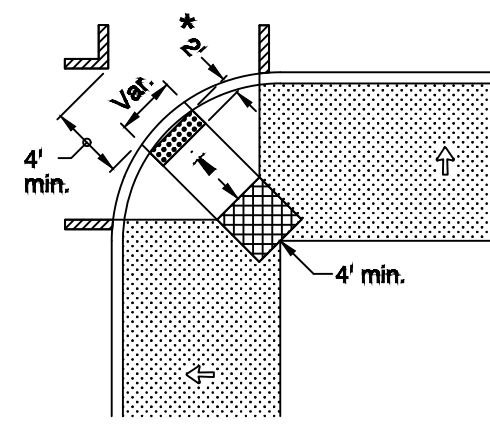

OPTION D
DIAGONAL RAMP (FOR WIDE SIDEWALKS)
Use in alterations only and when site constraints prohibit installing two ramps

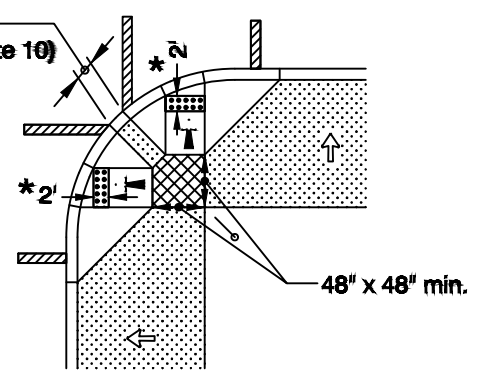

OPTION B
PERPENDICULAR RAMP (FOR WIDE SIDEWALKS)

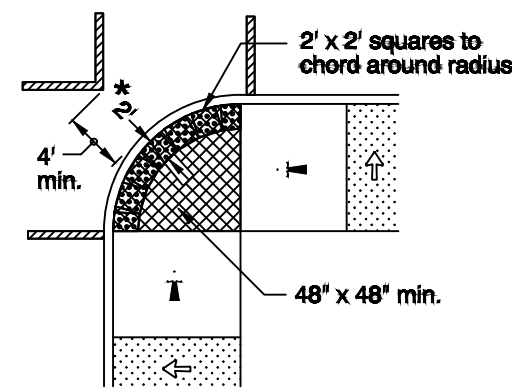

OPTION E
DIAGONAL-PARALLEL RAMP (FOR SIDEWALK WIDTHS ≥ RADIUS)
Use in alterations only and when site constraints prohibit installing two ramps

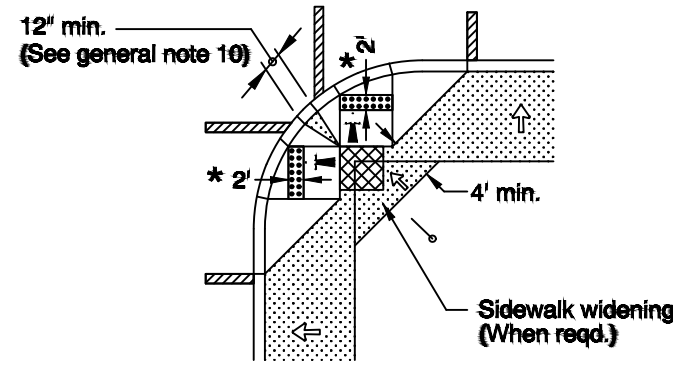

OPTION C
PERPENDICULAR RAMP (FOR NARROW SIDEWALKS)

GENERAL NOTES FOR ALL DETAILS:

1. Sidewalk ramp details are based on United States Access Board Standards.
2. See Std. Drgs. RD700 & RD701 for curbs. See Std. Drg. RD720 for sidewalks. See Std. Drgs. TMS03 & TMS30 for crosswalk markings, widths, etc. See Std. Drg. RD755 for sidewalk ramp details.
3. Tooled joints are required at all sidewalk ramp slope break lines.
4. Sidewalk curb ramp slopes shown are relative to the true level horizon (Zero bubble).
5. Place truncated dome detectable warning surface in the lower 2' adjacent to traffic of throat of ramp only. For details not shown, see Std. Drg. RD759.
6. Side flares that are not part of the path of travel may be any slope. Check the gutter flow depth to assure that the design flood does not overlap the back of sidewalk. If overtopping occurs place an inlet at upstream side or perform other approved design mitigation.

7. Return curb may be provided in lieu of flared slope only if protected from cross travel by landscaping or fixed barrier.
8. For the purpose of this drawing, a curb ramp is considered "perpendicular" if the angle between the longitudinal axis of the ramp and a line tangent to the curb at the ramp center is 75° or greater.
9. Ramps for paths intersecting a roadway should be full width of path, excluding flares. When a ramp is used to provide bicycle access from a roadway to a sidewalk, the ramp should be 8' wide.
10. When 2 curb ramps are immediately adjacent as in Options B & C, the curb exposure (e) between the adjacent side flares may range between 3" and full design exposure.
11. Only use options allowed by jurisdiction.
12. See project plans for details not shown.
13. See Traffic Standard Drawings for signal pole and pedestrian pedestal details.

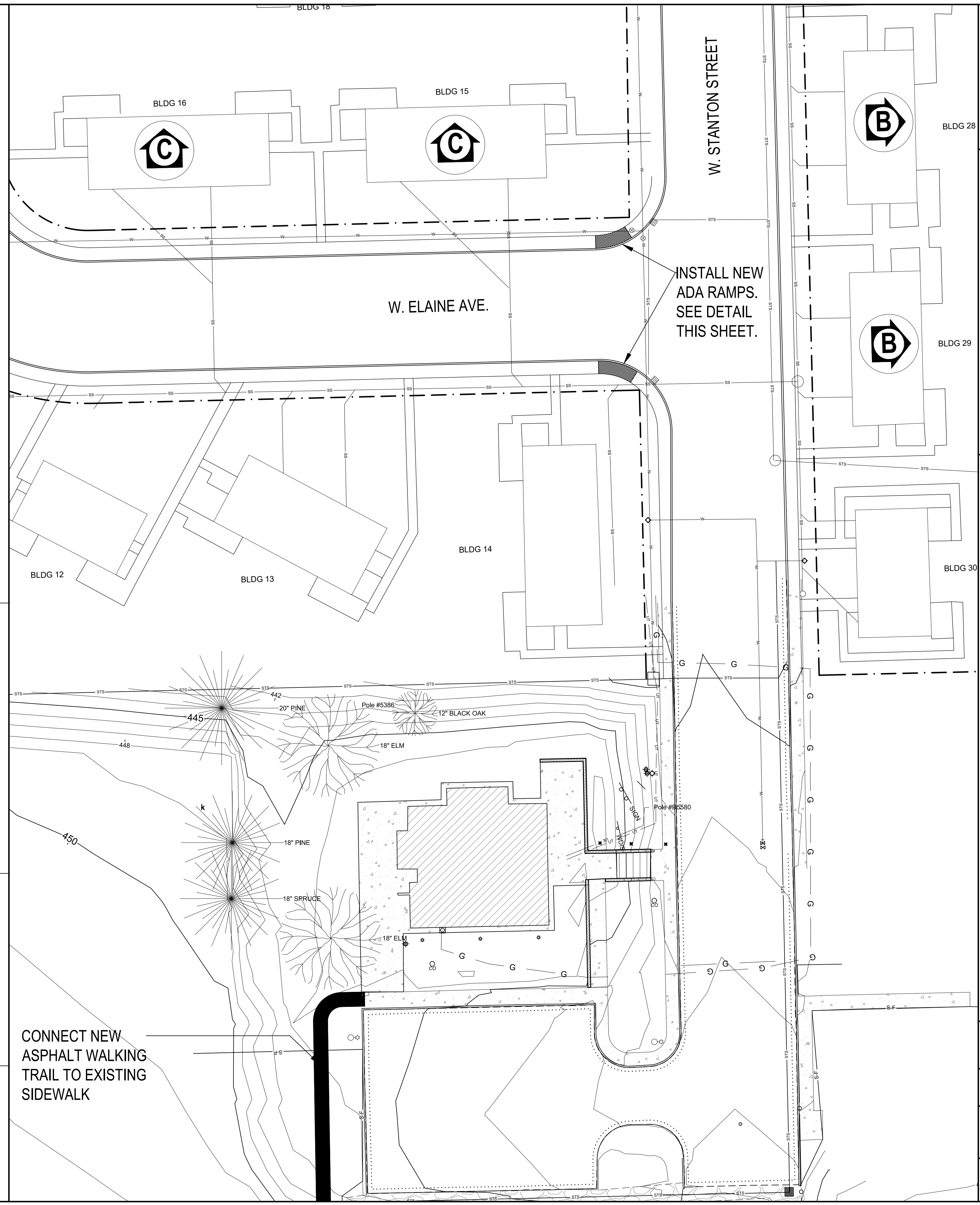

CONNECT NEW ASPHALT WALKING TRAIL TO EXISTING SIDEWALK

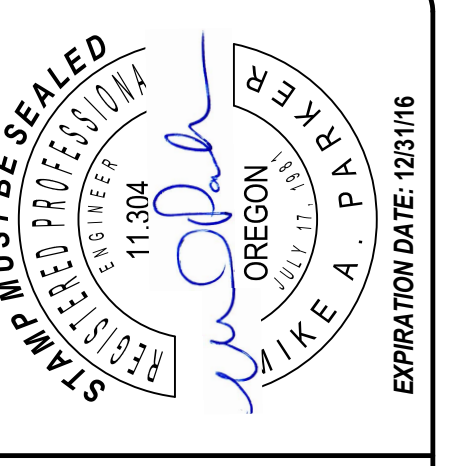

MAP Engineering, Inc.

P.O. BOX 667
WINCHESTER, OREGON 97495
PHONE: (541) 229-0365
EMAIL: mapeingineer@msni.com

HADCO OFFICE BUILDING

OFF-SITE SIDEWALK IMPROVEMENTS

PROJECT NAME: HADCO OFFICE BUILDING
DRAWING TITLE: OFF-SITE SIDEWALK IMPROVEMENTS

REVISION #:	DATE:	BY:	DATE:
2 - City Review	12/29/2016	MAP	12/29/2016

rd756.dgn 15-JAN-2016

RD756